

Please check the examination details below before entering your candidate information

Candidate surname

Other names

Centre Number

Candidate Number

Pearson Edexcel
Level 1/Level 2 GCSE (9–1)

--	--	--	--	--

--	--	--	--	--

Monday 11 November 2019

Afternoon (Time: 1 hour 30 minutes)

Paper Reference **1MA1/3H**

Mathematics

Paper 3 (Calculator)
Higher Tier



You must have: Ruler graduated in centimetres and millimetres, protractor, pair of compasses, pen, HB pencil, eraser, calculator. Tracing paper may be used.

Total Marks

Instructions

- Use **black** ink or ball-point pen.
- **Fill in the boxes** at the top of this page with your name, centre number and candidate number.
- Answer **all** questions.
- Answer the questions in the spaces provided – *there may be more space than you need.*
- You must **show all your working**.
- Diagrams are **NOT** accurately drawn, unless otherwise indicated.
- **Calculators may be used.**
- If your calculator does not have a π button, take the value of π to be 3.142 unless the question instructs otherwise.



Information

- The total mark for this paper is 80
- The marks for **each** question are shown in brackets – *use this as a guide as to how much time to spend on each question.*

Advice

- Read each question carefully before you start to answer it.
- Keep an eye on the time.
- Try to answer every question.
- Check your answers if you have time at the end.

Turn over ►

P58876RA

©2019 Pearson Education Ltd.

6/1/1/1/1



Pearson

Answer ALL questions.

Write your answers in the spaces provided.

You must write down all the stages in your working.

- 1 (a) Expand and simplify $(x + 5)(x - 9)$

$$x^2 - 9x + 5x - 45$$

$$\frac{x^2 - 4x - 45}{(2)}$$

- (b) Factorise fully $9x^2 + 6x$

$$3x(3x + 2)$$

(2)

(Total for Question 1 is 4 marks)

- 2 (a) Use your calculator to work out $\frac{29^2 - 4.6}{\sqrt{35 - 1.9^3}}$

Write down all the figures on your calculator display.

$$\frac{157.668255}{(2)}$$

- (b) Write your answer to part (a) correct to 4 significant figures.

$$\frac{157.7}{(1)}$$

(Total for Question 2 is 3 marks)



DO NOT WRITE IN THIS AREA

DO NOT WRITE IN THIS AREA

DO NOT WRITE IN THIS AREA

3 The scatter graph shows information about the marks a group of students got in a Science test and in a Maths test.

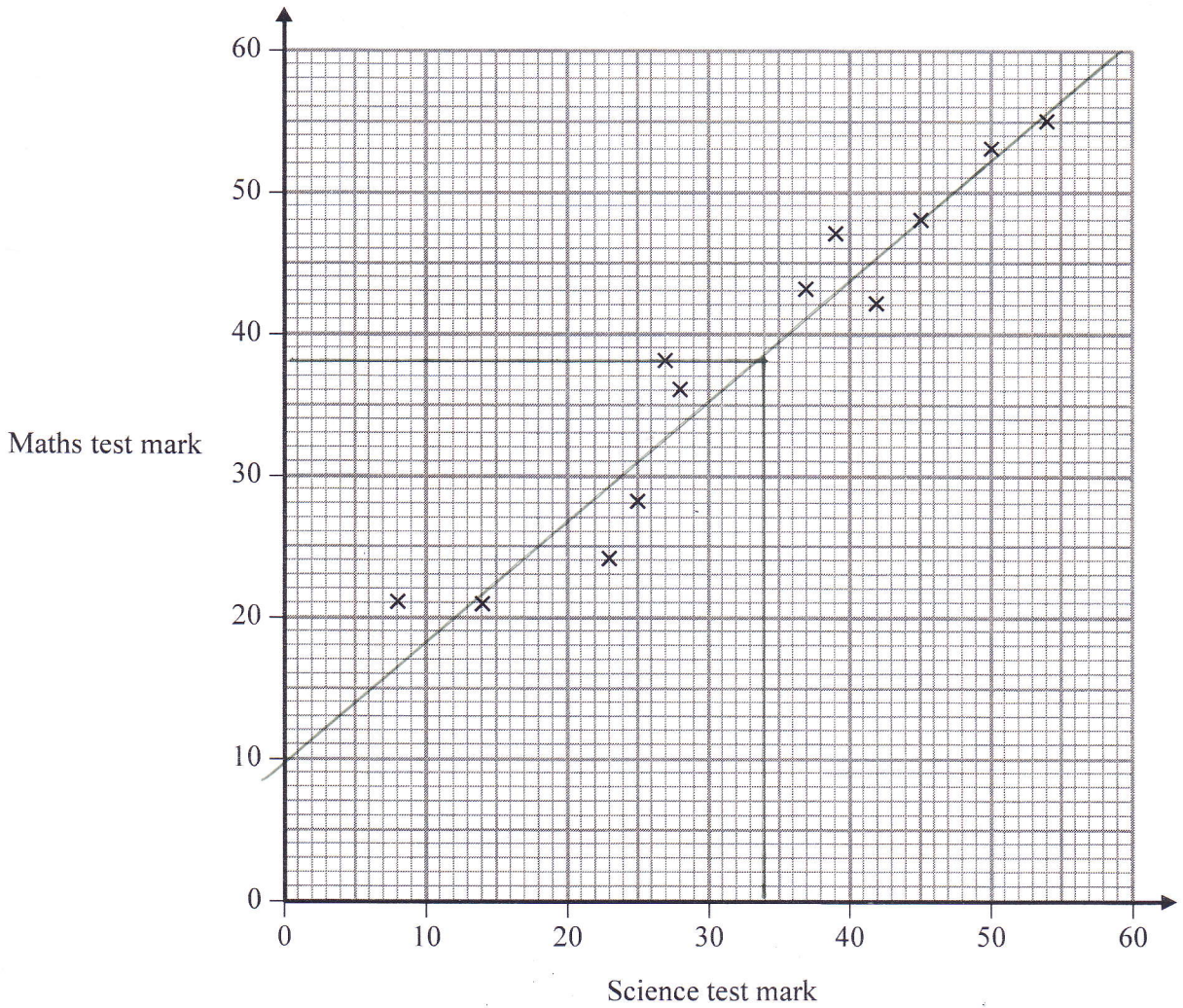

Jamie got a mark of 34 in the Science test.

Using the scatter graph, find an estimate for Jamie's mark in the Maths test.

38

(Total for Question 3 is 2 marks)



P 5 8 8 7 6 R A 0 3 2 4

4 The table gives information about the times taken, in seconds, by 18 students to run a race.

Time (t seconds)	Frequency	$\frac{oc}{mid}$	$f \times oc$
$5 < t \leq 10$	1	7.5	7.5
$10 < t \leq 15$	2	12.5	25
$15 < t \leq 20$	7	17.5	122.5
$20 < t \leq 25$	8	22.5	180
	18		335

Work out an estimate for the mean time.
Give your answer correct to 3 significant figures.

$$\text{Estimated Mean} = \frac{335}{18} = 18.6111$$

18.6 seconds

(Total for Question 4 is 3 marks)

DO NOT WRITE IN THIS AREA

DO NOT WRITE IN THIS AREA

DO NOT WRITE IN THIS AREA



5 Write 37 cm^3 in mm^3

$$1\text{ cm} = 10\text{ mm}$$

$$1\text{ cm}^3 = 10 \times 10 \times 10 = 1000\text{ mm}^3$$

$$37 \times 1000$$

$$37000 \text{ mm}^3$$

(Total for Question 5 is 1 mark)

6 Nimer was driving to a hotel.
He looked at his Sat Nav at 1330

Time	1330
Distance to destination	65 miles

Nimer arrived at the hotel at 1448

Work out the average speed of the car from 1330 to 1448
You must show all your working.

$$\begin{aligned} \text{time} &= 1\text{ hr } 18\text{ mins} \\ &= 1 \frac{18}{60}\text{ hours} \end{aligned}$$

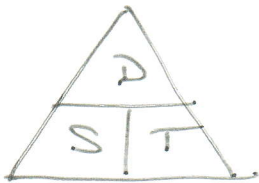

$$S = \frac{65}{1 \frac{18}{60}} = 50$$

$$50 \text{ mph}$$

(Total for Question 6 is 4 marks)



7 (a) Write 32460000 in standard form.

3 2 4 6 0 0 0 0

3.246×10^7
(1)

(b) Write 4.96×10^{-3} as an ordinary number.

0.00496

0.00496
(1)

Asma was asked to compare the following two numbers.

$A = 6.212 \times 10^8$ and $B = 4.73 \times 10^9$

She says,

“6.212 is bigger than 4.73 so A is bigger than B .”

(c) Is Asma correct?

You must give a reason for your answer.

No. She is incorrect as
 $10^8 < 10^9$

(1)

(Total for Question 7 is 3 marks)



8 The diagram shows a regular pentagon and a parallelogram.

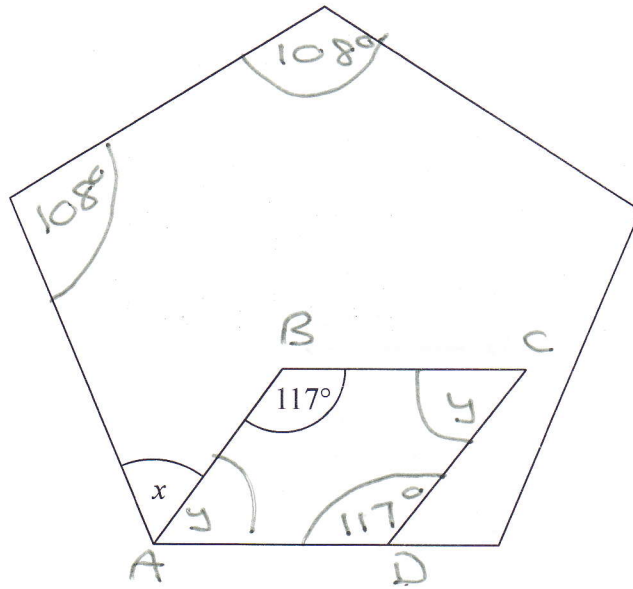

Work out the size of the angle marked x .
You must show all your working.

$$\angle CDA = 117^\circ \quad (\text{opposite angles in parallelogram equal})$$

$$\begin{aligned} \text{angles in pentagon} &= 3 \times 180 = 540^\circ \\ 540 \div 5 &= 108^\circ \end{aligned}$$

$$\begin{aligned} \text{in parallelogram} \quad 2y + 117 + 117 &= 360^\circ \\ 2y + 234 &= 360 \\ 2y &= 126 \\ y &= 63 \end{aligned}$$

$$\begin{aligned} x + y &= 108^\circ \\ \therefore x &= 108 - 63 = 45^\circ \end{aligned}$$

(Total for Question 8 is 4 marks)



9

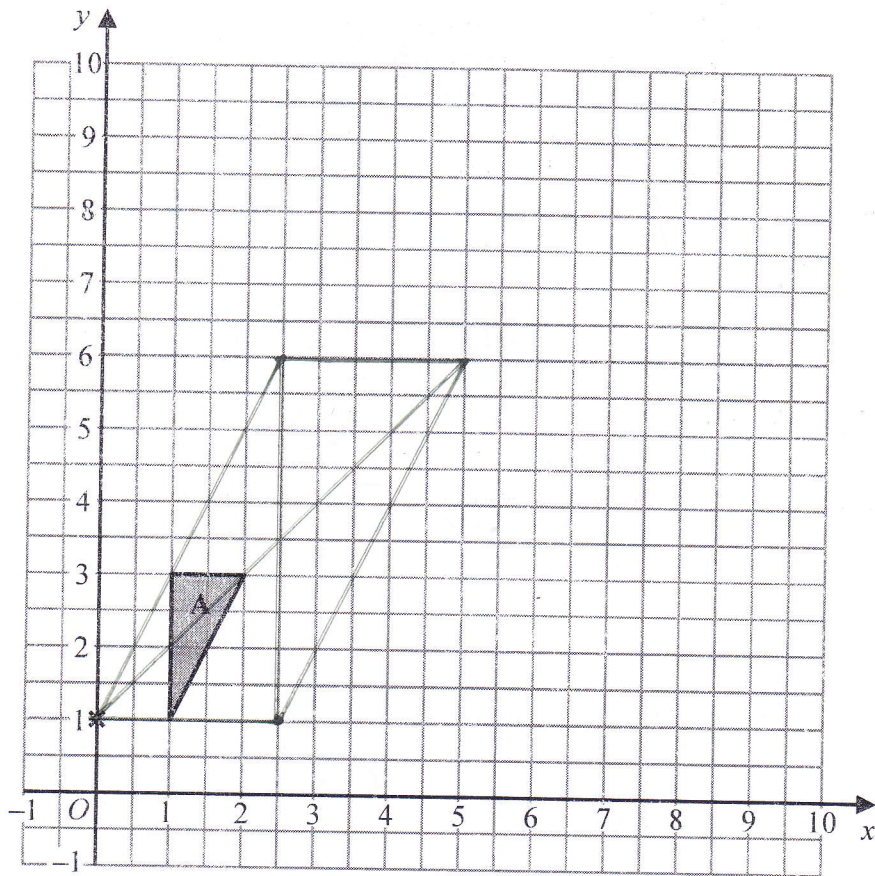

Enlarge triangle A by scale factor 2.5 with centre (0, 1)

(Total for Question 9 is 2 marks)

DO NOT WRITE IN THIS AREA

DO NOT WRITE IN THIS AREA

DO NOT WRITE IN THIS AREA

8



DO NOT WRITE IN THIS AREA

DO NOT WRITE IN THIS AREA

DO NOT WRITE IN THIS AREA

10 (a) Solve $\frac{9+x}{7} = 11-x$

$$9+x = 7(11-x)$$

$$9+x = 77-7x$$

$$7x+x = 77-9$$

$$8x = 68$$

$$x = \frac{68}{8} = 8.5$$

$x = \frac{8.5}{(3)}$

(b) Simplify $\frac{4(y+3)^3}{(y+3)^2} = 4(y+3)$

$\frac{4(y+3)}{(1)}$

(Total for Question 10 is 4 marks)



- 11 The probability tree diagram shows the probabilities that Bismah will be late for work on two days next week.

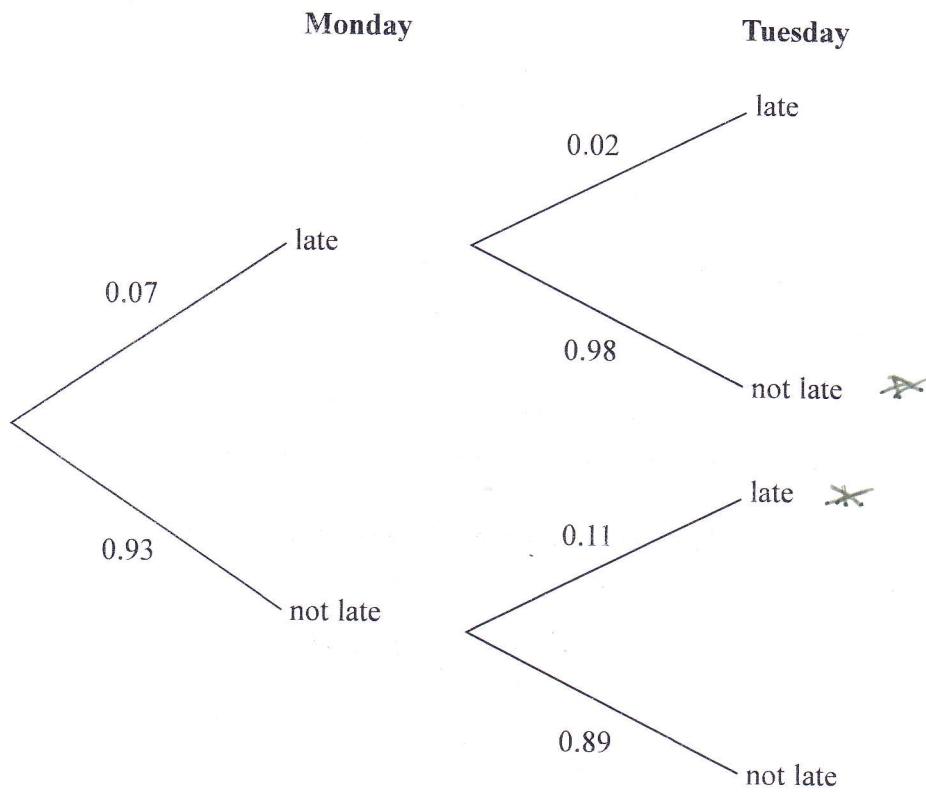

Calculate the probability that Bismah will be late on exactly one of the two days.

$$0.07 \times 0.98 + 0.93 \times 0.11$$

$$= 0.1709$$

0.1709

(Total for Question 11 is 3 marks)

DO NOT WRITE IN THIS AREA

DO NOT WRITE IN THIS AREA

DO NOT WRITE IN THIS AREA



DO NOT WRITE IN THIS AREA

DO NOT WRITE IN THIS AREA

DO NOT WRITE IN THIS AREA

12 The stem and leaf diagram shows information about the heights, in cm, of 23 sunflowers.

17	3	4	9				
18	6	8	8				
19	0	0	1	4	6	7	8
20	1	4	7	7	9	9	
21	4	8	8	9			

LOW

LQ

median

$$\text{median} = \frac{23+1}{2} = 12^{\text{th}}$$

Key: 17|3 represents 173 cm

HIGH

On the grid, draw a box plot for this information.

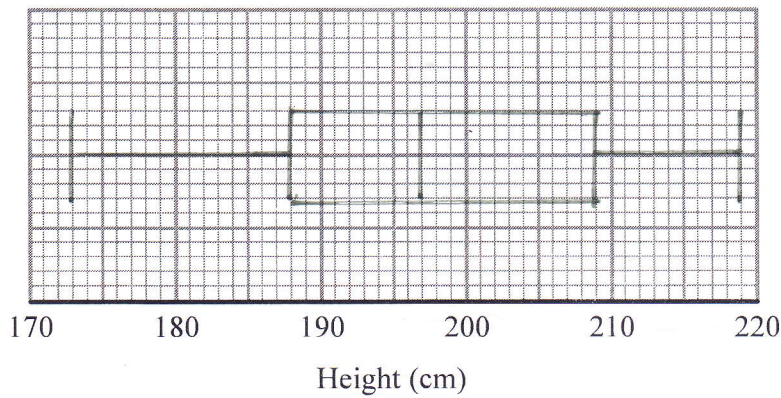

(Total for Question 12 is 3 marks)



13 Liquid A and liquid B are mixed together in the ratio 2:13 by volume to make liquid C.

Liquid A has density 1.21 g/cm^3

Liquid B has density 1.02 g/cm^3

A cylindrical container is filled completely with liquid C.

The cylinder has radius 3 cm and height 25 cm.

Work out the mass of the liquid in the container.

Give your answer correct to 3 significant figures.

You must show all your working.

$$\text{Volume C} = \pi r^2 h = \pi \times 3^2 \times 25 \\ = 225\pi \text{ cm}^3$$

$$225\pi$$

$$A : B$$

$$2 : 13$$

$$(\times 15\pi)$$

$$2 + 13 = 15$$

$$225\pi \div 15$$

$$= 15\pi$$

$$30\pi : 195\pi$$

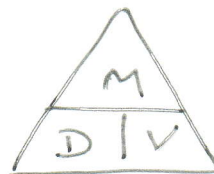

$$\text{Mass A} = 30\pi \times 1.21 = \frac{363}{10}\pi$$

$$\text{Mass B} = 195\pi \times 1.02 = \frac{1989}{10}\pi$$

$$\text{Total mass} = \frac{1176}{5}\pi$$

$$= 738.902$$

$$= 739 \text{ g (3sf)}$$

739

(Total for Question 13 is 4 marks)

DO NOT WRITE IN THIS AREA

DO NOT WRITE IN THIS AREA

DO NOT WRITE IN THIS AREA



- 14 A group of people went to a restaurant.
Each person chose one starter and one main course.

starter	main course
soup	lasagne
prawns	curry

the number of people who chose soup : the number of people who chose prawns = 2 : 3 $2+3=5$

Of those who chose soup,
the number of people who chose lasagne : the number of people who chose curry = 5 : 3 $5+3=8$

Of those who chose prawns,
the number of people who chose lasagne : the number of people who chose curry = 1 : 5 $1+5=6$

What fraction of the people chose curry?
You must show how you get your answer.

$$5 \times 8 \times 6 = 240$$

Assume 240 people

S : P

2 : 3

($\times 48$)

96 : 144

$$240 \div 5 = 48$$

96
L : C
5 : 3
($\times 12$)
60 : 36

$$96 \div 8 = 12$$

144
L : C
1 : 5
($\times 24$)
24 : 120

$$144 \div 6 = 24$$

Fraction who chose curry

$$= \frac{36 + 120}{240} = \frac{156}{240} = \frac{13}{20}$$

$$\frac{13}{20}$$

(Total for Question 14 is 4 marks)



- 15 Prove algebraically that the sum of the squares of any two consecutive even numbers is always a multiple of 4

$$\begin{aligned}(2n)^2 + (2n+2)^2 \\ &= 4n^2 + 4n^2 + 8n + 4 \\ &= 8n^2 + 8n + 4 \\ &= 4(2n^2 + 2n + 1)\end{aligned}$$

↑ as 4 is a factor must be a multiple of 4

(Total for Question 15 is 3 marks)

- 16 y is inversely proportional to the square of x .

$$y = 8 \text{ when } x = 2.5$$

Find the negative value of x when $y = \frac{8}{9}$

$$y \propto \frac{1}{x^2}$$

$$y = \frac{k}{x^2}$$

$$8 = \frac{k}{2.5^2}$$

$$k = 8 \times 2.5^2$$

$$k = 50$$

$$y = \frac{50}{x^2}$$

$$x^2 = \frac{50}{y}$$

$$x = \sqrt{\frac{50}{y}}$$

$$x = \sqrt{\frac{50}{\frac{8}{9}}}$$

$$x = \pm 7.5$$

$$x = -7.5$$

(Total for Question 16 is 3 marks)

DO NOT WRITE IN THIS AREA

DO NOT WRITE IN THIS AREA

DO NOT WRITE IN THIS AREA



17 Here is the graph of $y = x^2 - 3$

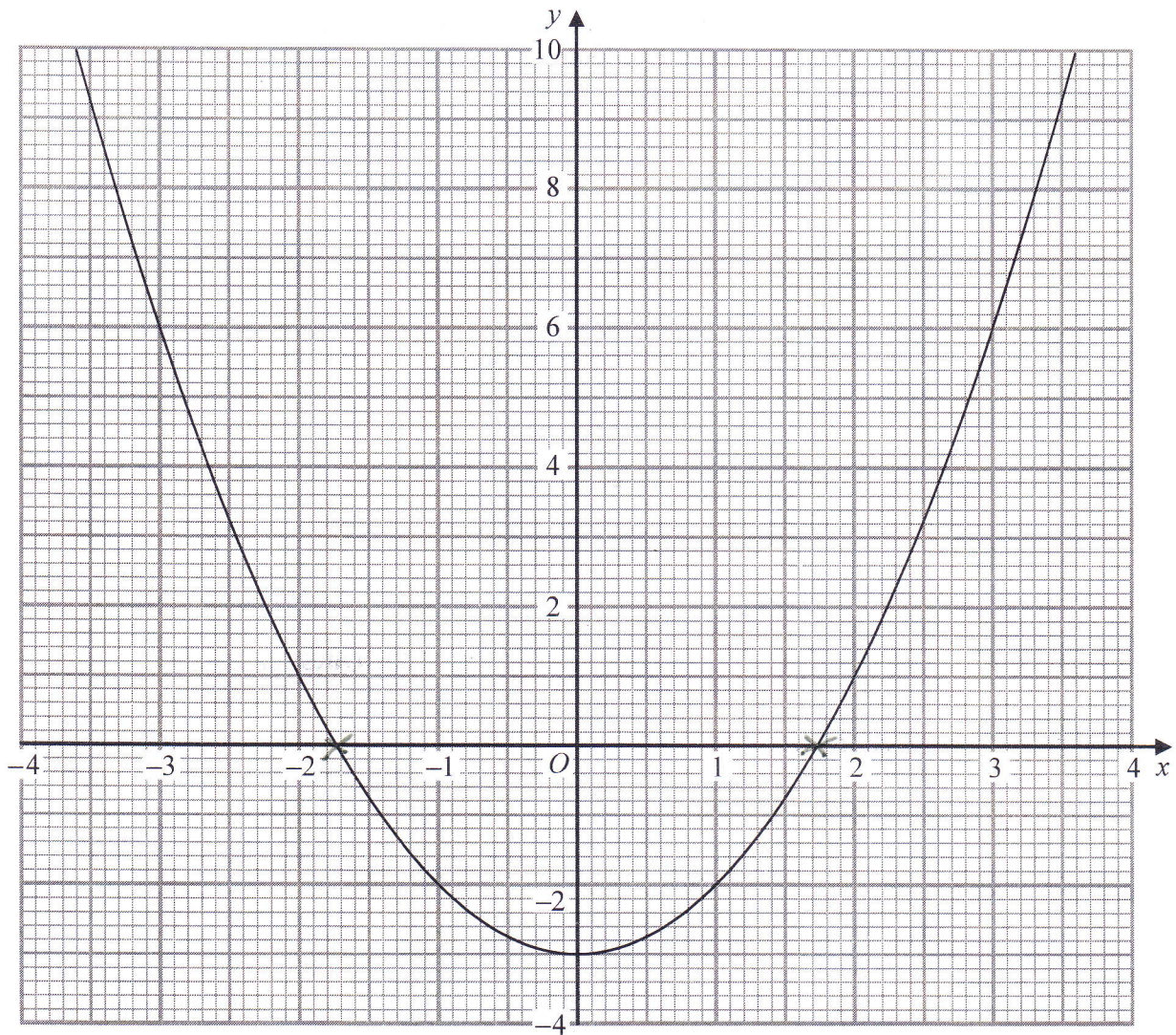

Use the graph to find estimates for the solutions to the equation $x^2 - 2x - 2 = 0$
 You must show how you get your solutions.

$$y = x^2 - 3$$

$$0 = x^2 - 2x - 2$$

complete the square

$$0 = (x-1)^2 - 1^2 - 2$$

$$0 = (x-1)^2 - 3$$

This is the graph above shifted

$$x = -0.7, 2.7$$

(Total for Question 17 is 4 marks)

1 unit right

∴ shift $x = -1.7$ and 1.7 one unit right



18 The diagram shows triangle ABC .

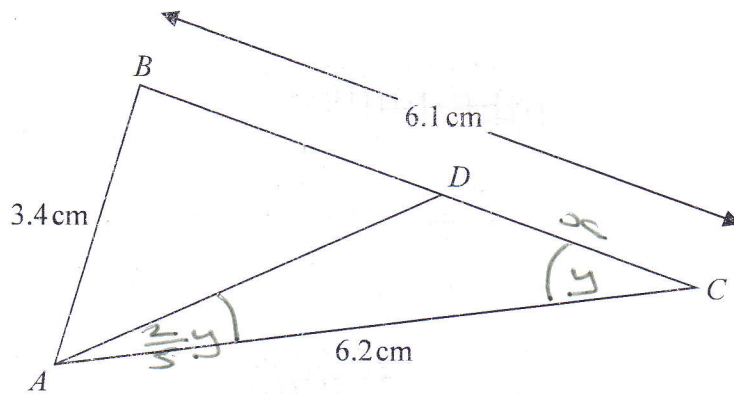

$AB = 3.4 \text{ cm}$ $AC = 6.2 \text{ cm}$ $BC = 6.1 \text{ cm}$

D is the point on BC such that

$$\text{size of angle } DAC = \frac{2}{5} \times \text{size of angle } BCA$$

Calculate the length DC .
Give your answer correct to 3 significant figures.
You must show all your working.

First find $\angle BCA$ (γ) COSINE RULE

$$\cos(\gamma) = \frac{6.1^2 + 6.2^2 - 3.4^2}{2 \times 6.1 \times 6.2}$$

$$\cos(\gamma) = \frac{6409}{7564}$$

$$\gamma = \cos^{-1}\left(\frac{6409}{7564}\right) = 32.08046913^\circ$$

$$\angle DAC = 12.83218765^\circ$$

$$\angle ADC = 180 - \text{ANS} - \frac{2}{5} \times \text{ANS} = 135.0873432^\circ$$

SINE RULE

$$\frac{\alpha}{\sin(12.83218765)} = \frac{6.2}{\sin(135.0873432)}$$

$$\alpha = \frac{6.2 \sin(12.83218765)}{\sin(135.0873432)} = 1.95034$$

$$\alpha = 1.95 \text{ cm}$$

(Total for Question 18 is 5 marks)

DO NOT WRITE IN THIS AREA

DO NOT WRITE IN THIS AREA

DO NOT WRITE IN THIS AREA



DO NOT WRITE IN THIS AREA

DO NOT WRITE IN THIS AREA

DO NOT WRITE IN THIS AREA

19 The graph shows information about part of a cyclist's journey.

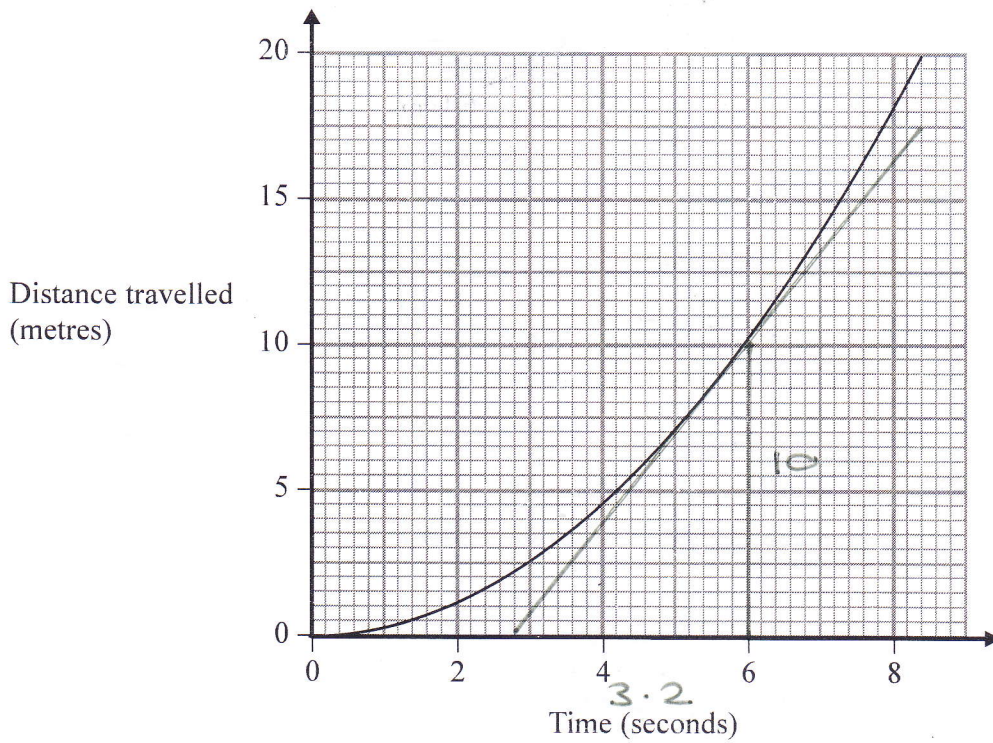

Work out an estimate of the speed, in m/s, of the cyclist at time 6 seconds.

$$\frac{10}{3.2} = 3.125$$

3.125 m/s

(Total for Question 19 is 3 marks)



20 Here are the first five terms of a sequence.

-1 0 3 5 8 15

Find an expression, in terms of n , for the n th term of this sequence.

	1	2	3	4	5
Term	-1	0	3	8	15
Diff	-2	-4	-6	-8	-10
		-2	-2	-2	-2
			-2n		

$n^2 - 2n$

(Total for Question 20 is 2 marks)

21 When a biased coin is thrown 4 times, the probability of getting 4 heads is $\frac{16}{81} = \left(\frac{2}{3}\right)^4$

Work out the probability of getting 4 tails when the coin is thrown 4 times.

$$\left(\frac{1}{3}\right)^4 = \frac{1}{81}$$

$$\frac{1}{81}$$

(Total for Question 21 is 2 marks)



DO NOT WRITE IN THIS AREA

DO NOT WRITE IN THIS AREA

DO NOT WRITE IN THIS AREA

22 Show that $\frac{7x-14}{x^2+4x-12} \div \frac{x-6}{x^3-36x}$ simplifies to ax where a is an integer.

$$\begin{aligned} & \frac{7(x-2) \times x(x^2-36)}{(x^2+4x-12)(x-6)} \\ = & \frac{7(\cancel{x-2}) \times x(\cancel{x+6})(\cancel{x-6})}{(\cancel{x+6})(\cancel{x-2})(\cancel{x-6})} \\ = & 7x \end{aligned}$$

(Total for Question 22 is 4 marks)



P 5 8 8 7 6 R A 0 1 9 2 4

- 23 The diagram shows a sector $OACB$ of a circle with centre O .
The point C is the midpoint of the arc AB .

The diagram also shows a hollow cone with vertex O .
The cone is formed by joining OA and OB .

$$\text{Volume of cone} = \frac{1}{3} \pi r^2 h$$

$$\text{Curved surface area of cone} = \pi r l$$

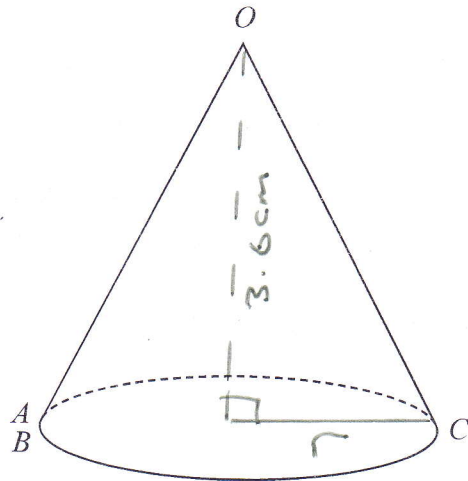
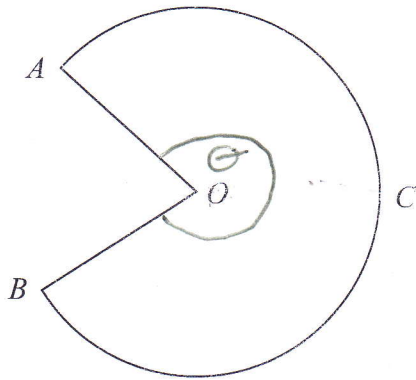
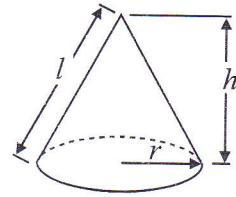

The cone has volume 56.8 cm^3 and height 3.6 cm .

Calculate the size of angle AOB of sector $OACB$.
Give your answer correct to 3 significant figures.
You must show all your working.

$$V = \frac{1}{3} \pi r^2 h$$

$$3V = \pi r^2 h$$

$$\frac{3V}{\pi h} = r^2$$

$$r = \sqrt{\frac{3V}{\pi h}}$$

$$r = \sqrt{\frac{3 \times 56.8}{\pi \times 3.6}} = 3.881580599 \text{ cm}$$

Pythagoras

$$OC = \sqrt{3.6^2 + r^2}$$

$$OC = 5.294021906 \text{ cm}$$

DO NOT WRITE IN THIS AREA

DO NOT WRITE IN THIS AREA

DO NOT WRITE IN THIS AREA



Circumference of base

$$\pi \times 3.881580599 \times 2 \\ = 24.38869019 \text{ cm}$$

$$\frac{\theta}{360} \times \pi \times 2 \times 5.294021906 = 24.388\dots$$

$$\theta = \frac{24.388\dots \times 360}{\pi \times 2 \times 5.294021906}$$

$$\theta = 263.9522542 \\ = 264^\circ \text{ (3 sf)}$$

264 °

(Total for Question 23 is 5 marks)



24 OXYZ is a parallelogram.

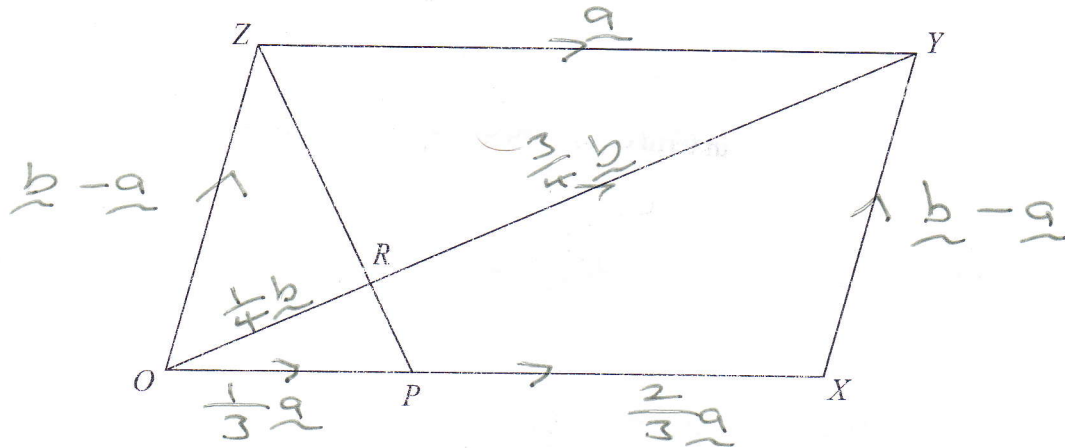

$$\vec{OX} = \underline{a}$$

$$\vec{OY} = \underline{b}$$

P is the point on OX such that $OP:PX = 1:2$

R is the point on OY such that $OR:RY = 1:3$

$$\vec{OP} = \frac{1}{3} \underline{a}, \quad \vec{PX} = \frac{2}{3} \underline{a}$$

$$\vec{OR} = \frac{1}{4} \underline{b}, \quad \vec{RY} = \frac{3}{4} \underline{b}$$

Work out, in its simplest form, the ratio ZP:ZR
You must show all your working.

$$\vec{OZ} = \vec{OY} + \vec{YZ} = \underline{b} - \underline{a}$$

$$\vec{ZP} = \vec{ZO} + \vec{OP} = -(\underline{b} - \underline{a}) + \frac{1}{3} \underline{a}$$

$$= \frac{4}{3} \underline{a} - \underline{b} = \frac{4}{3} (\underline{a} - \frac{3}{4} \underline{b})$$

$$\vec{ZR} = \vec{ZO} + \vec{OR} = -(\underline{b} - \underline{a}) + \frac{1}{4} \underline{b}$$

$$= -\frac{3}{4} \underline{b} + \underline{a}$$

$$\vec{ZP} : \vec{ZR}$$

$$\frac{4}{3} (\underline{a} - \frac{3}{4} \underline{b}) : \underline{a} - \frac{3}{4} \underline{b}$$

$$\frac{4}{3} : 1$$

$$4 : 3$$

$$4 : 3$$

(Total for Question 24 is 5 marks)

TOTAL FOR PAPER IS 80 MARKS

DO NOT WRITE IN THIS AREA

DO NOT WRITE IN THIS AREA

DO NOT WRITE IN THIS AREA

